

TE

TODD ENGLISH

ROTISSERIE ACCESSORY SET

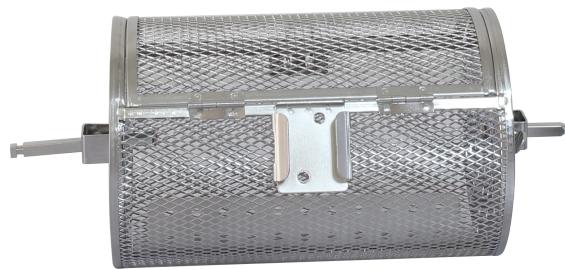

ROLLING CAGE

USE

- Place food such as french fries inside the rolling cage and close.
- For assembly, use the rotisserie rod and place through the rolling cage (1 & 2). Then insert food into rolling cage (3) and close (4). Place inside the unit (5). The rolling cage fits inside of the unit by placing one end in first then the other on the grooves inside the unit. Remove using the rotisserie handle (6).
- Please see below for assembly images.

CARE

- Hand washing is recommended.

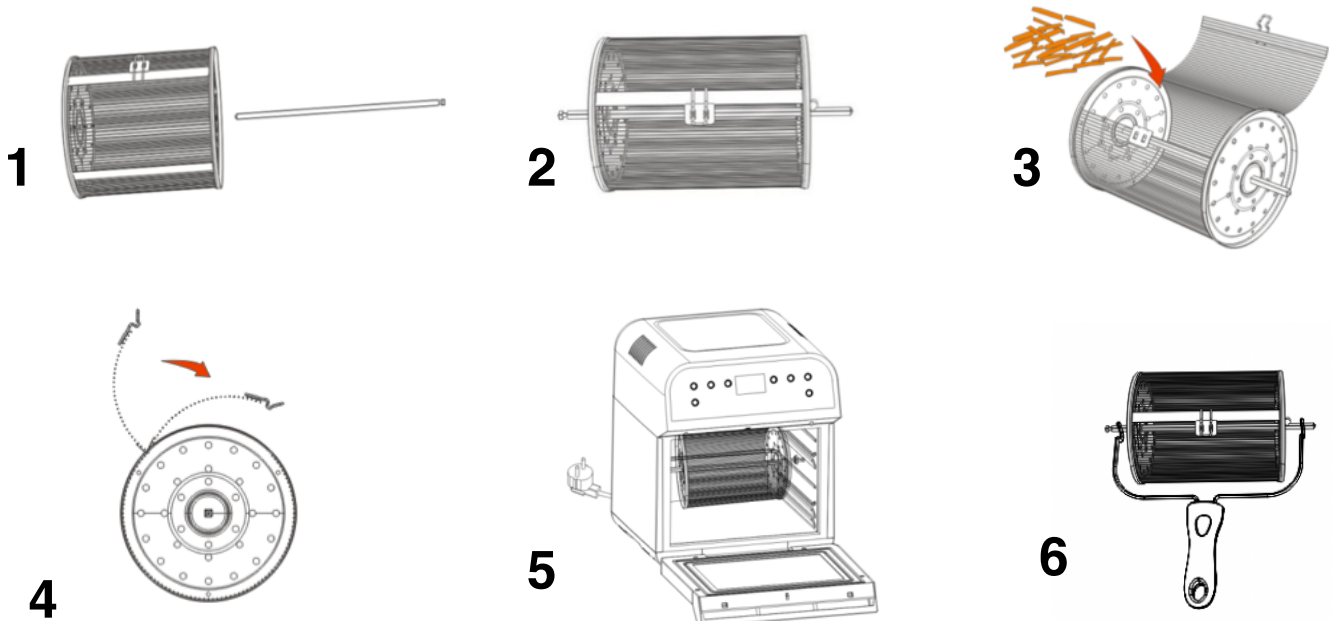



SKEWER RACK

USE

- Place food on skewers.
- For assembly, use the rotisserie rod, place through the center of the skewer rack attaching one end at a time then assemble other end on the rod(1-4)). Then insert food on the skewers(5). To place the skewers on the rack, put one skewer per groove (6) on the rack. The skewers will lock in place (7-8). Once all skewers are on the rack, place inside the unit (9). The skewer rack fits inside of the unit by placing one end in first then the other on the groves inside the unit. Remove using the rotisserie handle.
- Please see below for assembly images.

CARE

- Hand washing is recommended.

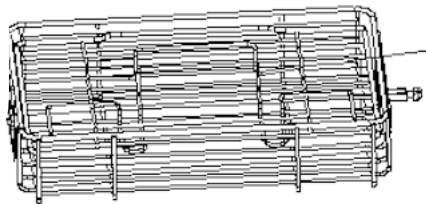
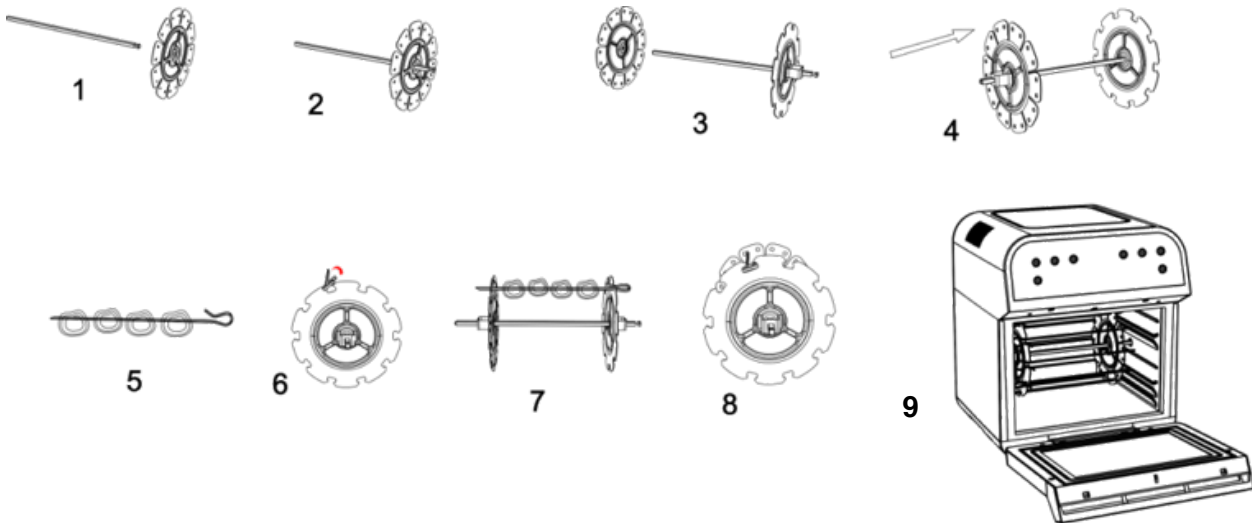

GRILL CAGE

USE

- Place food inside for grilling such as chicken or steak. The grill cage fits inside of the unit by placing one end in first then the other on the groves inside the unit. Remove using the rotisserie handle.

CARE

- Hand washing is recommended.

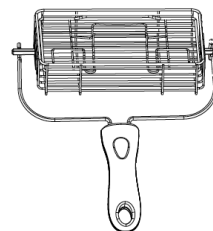

LIMITED ONE YEAR WARRANTY

This warranty covers all defects in workmanship or materials in the parts arising under normal use and care in this product for a period of 12 months from the date of purchase provided you are able to present a valid proof-of-purchase. A valid proof-of-purchase is a receipt specifying item, date purchased, and cost of item. A gift receipt showing item and date of purchase is an acceptable proof-of-purchase. Product is intended for household use only. Any commercial use voids the warranty.

This warranty covers the original retail purchaser or gift recipient. During the applicable warranty period within normal household use, we will repair or replace, at our discretion, any part which proves defective, or replace unit with a comparable model. Shipping and handling costs are not included for warranty replacements and are the responsibility of the customer.

To obtain service under the terms of this warranty, call our customer care department at 312-526-3760 (Monday- Friday 10:00AM-6:00PM CST), or send an email to customercare@alliedrich.net. Please provide the model number listed on the bottom of this page when contacting us.

THIS LIMITED WARRANTY COVERS UNITS PURCHASED AND USED WITHIN THE UNITED STATES AND DOES NOT COVER:

- Damages from improper installation.
- Damages in transit.
- Defects other than manufacturing defects.
- Damages from misuse, abuse, accident, alteration, lack of proper care and maintenance, or incorrect current or voltage.
- Damage from service by other than authorized dealer or service center.
- Shipping and handling costs.
- This warranty gives you special legal rights and you may also have other rights to which you are entitled which may vary from state to state.

Manufacturer does not assume responsibility for loss or damage for return shipment. We recommend that you keep your original packaging should you require repair service. Before returning product please contact our customer care department for return authorization. When returning product for repair please include your full name, return address, and daytime phone number. Also include a brief description of the problem you are experiencing and a copy of your sales receipt or other proof of purchase in order to validate warranty status.

MODEL TE12RAB

TE

TODD ENGLISH